

Introduction

Wind posts are a common way of providing lateral support to tall masonry walls in modern steel-framed buildings.

In situations where the walls are also required to provide fire resistance between two compartments (or at a boundary position), the fire protection applied to the wind posts must also maintain the fire separation across the wall construction at that point. That is, in addition to providing fire protection to the steel to a critical temperature of $T_{550}^{\circ}\text{C}$, it must also be capable of maintaining the wall integrity and the insulation requirements of $T_{140}^{\circ}\text{C}$ mean rise and $T_{180}^{\circ}\text{C}$ maximum rise to the unexposed face.

2-Sided Wind Post Encasement

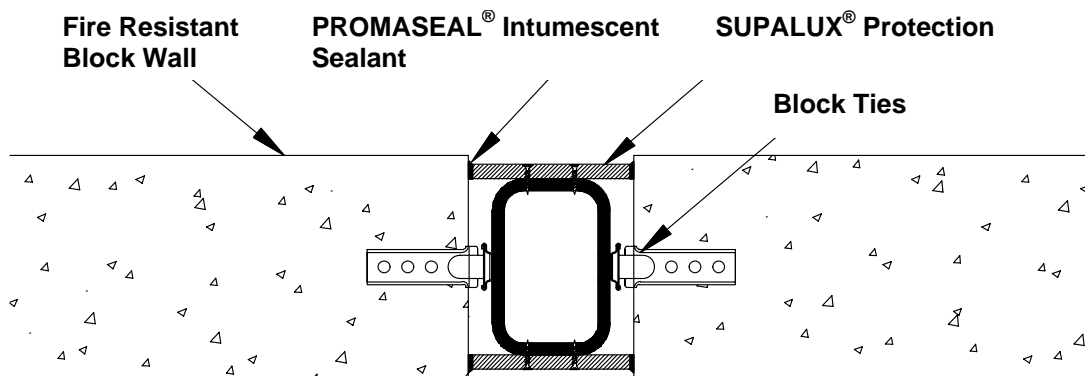

RHS and SHS steel sections are frequently used for wind posts and the openings in the fire resistant wall may be typically 40mm wider than the steel section itself; in order to accommodate the block ties.

The wind post will normally require fire protection for the same fire resistance period as the supported separating wall.

Fire attack will normally be considered to occur from either face, but not from both faces simultaneously.

Under these circumstances the thickness of SUPALUX® required to maintain fire separation across the wall, will usually be greater than the thickness required simply to protect the steel alone. The actual thickness of SUPALUX® required depending on number of factors.

Table 1 (shown overleaf), conveniently indicates the SUPALUX® thickness required for common RHS and SHS steel sections, which are grouped according to the 'Exposed Face Width' of the Steel Section (not the opening in the block-work) and the actual 'Thickness of the Steel Section'.

Note:

The data provided in table 1 assumes that the opening in the block-work is not greater than 40mm more than the wind post face width.

For openings that exceed 40mm, and for steel section that do not appear to be covered by the table (ie: for thinner steel sections, larger posts or UC sections); consult Promat Technical Services Department for further details.

AUTHORITY: Promat Recommendation - Based on in-house knowledge and Technical Experience

Technical Data
Sheet – 012

Page 1 of 3
(Sept 2005)



Promat UK Limited
Technical Services Department
The Sterling Centre, Eastern Road
Bracknell, Berkshire RG12 2TD
Tel: 01344 381 400
Fax: 01344 381 401
E-mail: technicaluk@promat.co.uk



Table 1

2-Sided Wind Post Encasement

Supalux Thickness Required to Provide 120 minutes Protection to RHS and SHS Wind Posts, and Maintain 120 minutes Fire Resistance Across the Compartment Wall

Steel Section Thickness	5mm	6.3mm	8mm	10mm	12.5mm	16mm
Face Width Of Steel Wind Post (As Viewed From Front)	50 mm	12 mm	12 mm	12 mm	12 mm	12 mm
	60 mm	15 mm	12 mm	12 mm	12 mm	12 mm
	70 mm	15 mm	12 mm	12 mm	12 mm	12 mm
	80 mm	15 mm	15 mm	12 mm	12 mm	12 mm
	90 mm	15 mm	15 mm	12 mm	12 mm	12 mm
	100 mm	20 mm	15 mm	15 mm	12 mm	12 mm
	120 mm	20 mm	20 mm	15 mm	15 mm	12 mm
	140 mm	20 mm	20 mm	15 mm	15 mm	12 mm
	150 mm	20 mm	20 mm	20 mm	15 mm	15 mm
	160 mm	20 mm	20 mm	20 mm	15 mm	15 mm
	180 mm	25 mm	20 mm	20 mm	15 mm	15 mm
	200 mm	25 mm	20 mm	20 mm	20 mm	15 mm
250 mm	25 mm	25 mm	20 mm	20 mm	15 mm	

Fixings

- Where SUPALUX® panels will remain recessed, or flush with the block wall; the SUPALUX® protection may be fastened directly to both faces of the steel sections using either No.8 steel self-tapping screws at nominal 300mm centres or 3.6mm (or 3.7mm) steel shot fired nails at 300mm nominal centres. Self-drilling, self-tapping screws may also be used.

The screw or nails must penetrate at least 10mm beyond the interface of the SUPALUX® and the steel, and are staggered, being approximately 30mm from alternate edges of the steel post. At any horizontal SUPALUX® joint, there must be fixings 20mm above and below joint. The screws and nails may be fitted with or without steel washers (Promat recommends the use of washers).

A nominal 3mm gap must be left between the edge of the SUPALUX® panel and the block-work. This must be fully filled with Promat PROMASEAL® Intumescent Sealant.

Where horizontal joints occur, a nominal 3mm gap *must* also be left between SUPALUX® panels and fully filled with Promat PROMASEAL® Intumescent Sealant.

- Alternatively, the SUPALUX® panels may be fastened to the face of the block wall, through 75mm x 9mm thick SUPALUX® fillets either side of the hollow section into non-combustible plugs. The fixing should penetrate the block work by a minimum of 30mm and be a minimum of 50mm from the edge of the block-work.

With this form of cladding, an internal SUPALUX® cover strip (minimum 6mm thick) must be fitted behind any horizontal SUPALUX® joint. The cover strip must leave a minimum 6mm clearance to the steel post.

Note:

For wind posts that project beyond the face of the block wall, consult Promat Technical Services Department.

AUTHORITY: Promat Recommendation - Based on in-house knowledge and Technical Experience

Technical Data Sheet – 012

Page 2 of 3
(Sept 2005)



Promat UK Limited
Technical Services Department
The Sterling Centre, Eastern Road
Bracknell, Berkshire RG12 2TD
Tel: 01344 381 400
Fax: 01344 381 401
E-mail: technicaluk@promat.co.uk



1-Sided Wind Post Encasement

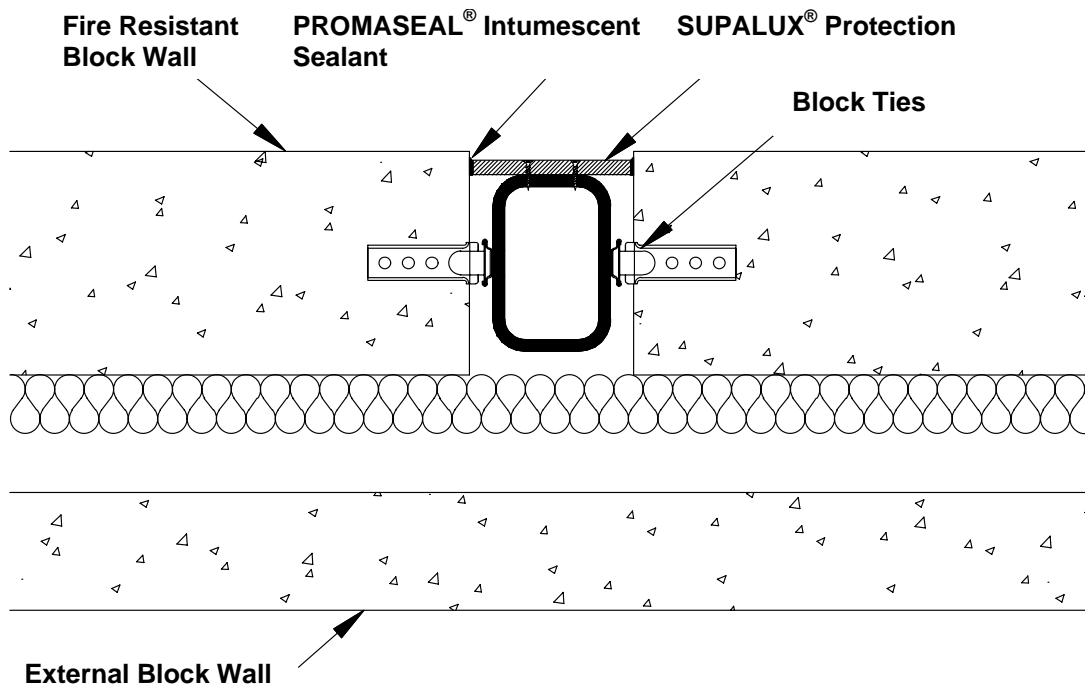

When RHS or SHS wind post are incorporated into the inner leaf of an external wall, the outer masonry leaf will normally provide the fire separation required (any insulation to the cavity should be fire resistant to fire stop the cavity). The protection to the wind post under these circumstances may be regarded as a normal 1-sided steel section exposure, and additional consideration for increasing the SUPALUX® thickness is not required.

The section factor (A/V) is calculated, using the 'opening width' in the block wall as the heating perimeter (A), and the steel section cross sectional area (V) from steel section tables.

The method used for fastening the SUPALUX® panels, is the same as for the 2-Sided Wind Post Encasement described earlier.

Table 2 below, indicates the thickness of SUPALUX® board required.

Table 2

1-Sided Wind Post Encasement

SUPALUX® Thickness Required to Provide 120 minutes Protection to RHS and SHS Wind Posts Where 120 minutes Compartmentation is Achieved by an External Masonry Leaf

Maximum Wind Post Section Factor A/V (m^{-1})	Thickness of Supalux Protection
47	12 mm
61	15 mm

Note: For any section not covered by table 2, consult Promat Technical Services Department.

AUTHORITY: Promat Recommendation - Based on in-house knowledge and Technical Experience

Technical Data Sheet – 012

Page 3 of 3
(Sept 2005)



Promat UK Limited
 Technical Services Department
 The Sterling Centre, Eastern Road
 Bracknell, Berkshire RG12 2TD
 Tel: 01344 381 400
 Fax: 01344 381 401
 E-mail: technicaluk@promat.co.uk

