

2 LAYERS OF 12.5mm PLASTERBOARD FOIL BACKED BOARD FIXED TO TIMBER STUDS. STANDARD BOARD TO WALL FACE, TAPED & FILLED AT JOINTS. BOARDS FIXED AT 150mm MAXIMUM CENTRES WITH 2.8Øx50mm ANNULAR SHANK NAILS ENSURING THE JOINTS ARE STAGGERED BETWEEN THE TWO LAYERS.

9mm STRUCTURAL SHEATHING BOARD (E.G. OSB BOARD) FIXED TO TIMBER STUDS WITH 2.8Øx50mm ANNULAR SHANK NAILS AT 150mm MAXIMUM CENTRES.

15mm SUPALUX (OR 2 x 9mm SUPALUX) FASTENED WITH 2.8Øx50mm ANNULAR SHANK NAILS AT 150mm MAXIMUM CENTRES.

150mm THICK 33kg/m³ ROCK WOOL INSULATION BETWEEN TIMBER STUDS.

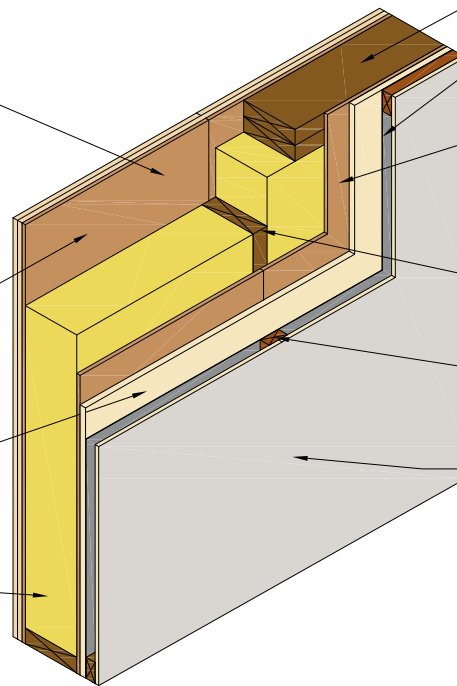

2 140x50mm GRADE C16 TIMBERS FORMING TOP PLATE.

BREATHER MEMBRANE.

9mm STRUCTURAL SHEATHING BOARD (E.G. OSB BOARD) FIXED TO TIMBER STUDS WITH 2.8Øx50mm ANNULAR SHANK NAILS AT 150mm MAXIMUM CENTRES.

MINIMUM 140x50mm GRADE C16 TIMBER STUDS AT 600mm MAXIMUM CENTRES.

25x38mm TREATED TIMBER BATTENS AT 600mm MAXIMUM CENTRES.

EXTERNAL GRADE CLADDING BOARD/ SYSTEM FIXED DIRECTLY THROUGH TO TIMBER STUDWORK OR TO MINIMUM 25x38mm TIMBER BATTENS (WITH BATTENS FIXED TO TIMBER STUDWORK WITH 3.2Øx75mm ANNULAR SHANK NAILS AT 150mm CENTRES. (IN ACCORDANCE WITH BUILDING CONTROL OFFICE GUIDANCE)

Construction:

Typically minimum 140mm-deep structural frame with timber studs at maximum 600mm centres, clad internally with two layers of 12.5mm thick plasterboard (with vapour control layer) and a layer of 9mm thick structural sheathing board (e.g. OSB). The void between the timber studs is filled with 140mm thick x minimum 33kg/m³ rock wool (thickness increased to fully fill the void if a deeper stud is used). The external build-up comprises of one layer of 9mm structural sheathing board, one layer of 15mm Supalux® (or two layers of 9mm Supalux®) and a layer of breather membrane. An external grade cladding board or system should be fixed either through to timber studwork or into the timber battens.

Overall Thickness:

Nominal 200mm (based on construction above, excluding external cladding system)

Maximum Height:

3000mm

Nominal Weight:

80kg/m²

Fire Performance:

60 minutes integrity and insulation, BS 476: Part 21

U Value:

0.26 W/m²K (based on construction above, rock wool insulation λ 0.035 W/mK)

Important Note:

All timber frame members should be designed in accordance with the requirements of BS 5268 (Structural use of timber).

AUTHORITY: Promat Recommendation - Based on in-house knowledge and Technical Experience

Technical Data
Sheet – 044
Page 1 of 1
(Oct 2007)



Promat UK Limited
Technical Services Department
The Sterling Centre, Eastern Road
Bracknell, Berkshire RG12 2TD
Tel: 01344 381 400
Fax: 01344 381 401
E-mail: technicaluk@promat.co.uk

