

Introduction:

VERMICULUX® is a lightweight non-combustible board specially designed to provide up to 240 minutes fire protection to structural steelwork.

The following recommendations should be adopted where a fire rated partition system, running in the same plane as a VERMICULUX® protected steel beam, is connected to the underside of the beam or where a fire rated partition system is connected to one or both flanges of a VERMICULUX® protected steel column.

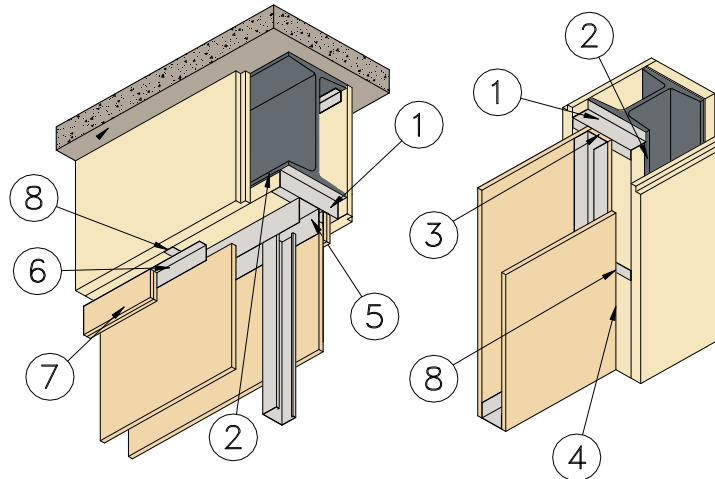

Construction Details:

- The steel Z brackets, 0.9mm to 1.2mm thick with flanges 32mm wide (1), are fastened to the beam or column flange (2) with shot fired 3.7mm x 16mm steel nails (Hilti ENK 16 S12 or equivalent) at 300mm maximum centres. The Z brackets are the same length as the width of the beam/ column and are spaced at 600mm nominal centres along the length of the flange.
- The dimension of the web of the Z brackets should be made 6mm longer than the thickness of the VERMICULUX®, to allow for a tolerance between the flange of the beam and the VERMICULUX® board (the web of the Z bracket should be 3mm longer where used for a column). The width of the VERMICULUX® should be cut 6mm wider than the width of flange of the beam/column, to allow for a 3mm tolerance between the web of the beam/column and the VERMICULUX® cheek boards.
- When connecting to a column, the steel starter stud channel is fastened to the Z bracket through at least one layer of the facing board (3), with steel drywall screws.
- The partition facing boards extend tight up to the VERMICULUX® casing (4) and any gaps between the partition and the VERMICULUX® casing should be sealed using PROMASEAL® intumescent sealant.
- The partition must also include a deflection head assembly where it is fastened to a supporting beam, to allow for the movement of the steel beam in a fire situation. The Building Regulations require that provision for a deflection should be 40mm, or the span (in mm) of the beam divided by 100 (L/100), whichever is the larger.
- If a SUPALUX® partition is installed, a 40mm movement head may be provided using a deep head channel (5) and ensuring that the partition facing boards overlap the head track, but have sufficient clearance to the underside of the beam to accommodate the required deflection. A light gauge angle is fastened to the Z brackets (6) to carry a double layer of the SUPALUX® board (7) to cover the expansion gap. The board thickness and further details are given in the Promat Certifire document CF 420A. The depth is adjusted to suit the amount of deflection required. For other partitions, consult with the manufacturer concerned.
- For fire protection periods up to 2hrs, provided that the exposed length of the steel Z bracket (8) does not exceed 50% of its total length, then the steel Z brackets may be left unprotected as shown. For greater percentage of exposed length, and for longer periods of fire protection, the Z sections must be covered with a minimum of 9mm SUPALUX® in order to maintain compartmentation across the partition.

AUTHORITY: WF Assessment Report No: 161748

Technical Data
Sheet – 047

Page 1 of 2
(Mar 2009 rev 3)



Promat UK Limited
Technical Services Department
The Sterling Centre, Eastern Road
Bracknell, Berkshire RG12 2TD
Tel: 01344 381 400
Fax: 01344 381 401
E-mail: technicaluk@promat.co.uk



Steel Protection Performance:

Up to 240 minutes protection, in terms of the load bearing capacity, criteria to BS 476: Part 21: 1987.

Important Notes:

Fixing details as shown are suitable for providing fire protection to steel beams of maximum size 686mm x 325mm. Alternative fixing methods may be required for deeper beams. Contact Promat UK Technical Services department for further information.

Steel beams and columns must be supported from appropriate masonry/ concrete or steel constructions that have a fire resistance of at least that required for the protected beam or column in terms of BS476: Part 21: 1987 and are capable of providing adequate support to the constructions for the required period of fire resistance.

It is assumed that the partition system that is connected to the steel beam or column is a steel framed drywall system that has a fire resistance of at least that required for the protected beam or column in terms of BS476: Part 22: 1987.

Where a partition meets the underside of a beam, a deflection head assembly must be fitted to allow for the bowing of the steel beam in a fire situation. The minimum allowance for deflection should be 40mm or the span (in mm) of the beam divided by 100 (L/100), whichever is the larger. This is required so that the deflection of the beam does not result in damage to the partition and the partition does not damage the VERMICULUX® encasement.

The thickness of VERMICULUX® required to provide the period of fire protection, depends on the A/V section factor and the limiting temperature of the steel. Where a limiting temperature has not been provided, then Promat will have specified the protection thickness to the default value of 550°C.

However, the user should be aware that this default temperature may not necessarily be adequate, or appropriate, for the proposed use for which the building is intended, and this default temperature specification must be verified with the structural fire designer concerned.

The load on the structure at the time of the fire can also be calculated by treating it as an accidental limit state. If used, this will allow structural fire designers to specify a limiting or failure temperature for a given structural section, to be provided to the fire protection contractor. Where the limiting temperature is provided, Promat will specify the structural steel protection thickness, appropriate to that temperature.

If the span of the beam is large, or the amount of movement that the deflection head assembly can accommodate is limited, then the thickness of VERMICULUX® for the beam encasement should be chosen using a maximum limiting steel temperature of 400°C. This will minimise the potential bowing of the beam.

If it is also required to provide fire insulation across the beam or column in order to maintain compartmentation to the criteria of BS 476: Part 22: 1987 (maintaining insulation to average temperature rise of 140°C, maximum temperature rise 180°C), then the *minimum* thickness of the VERMICULUX® board on each side of the beam or column must be as follows:

Fire resistance – minutes	Board thickness - mm
60	20
90	25
120	30
150	35
180	40
240	50

Thicker board may be required to provide the required period of fire protection to the steelwork in terms of the loadbearing capacity to BS476: Part 21:1987

AUTHORITY: WF Assessment Report No: 161748

Technical Data Sheet – 047

Page 2 of 2
(Mar 2009 rev 3)



Promat UK Limited
Technical Services Department
The Sterling Centre, Eastern Road
Bracknell, Berkshire RG12 2TD
Tel: 01344 381 400
Fax: 01344 381 401
E-mail: technicaluk@promat.co.uk

