

Section through beams

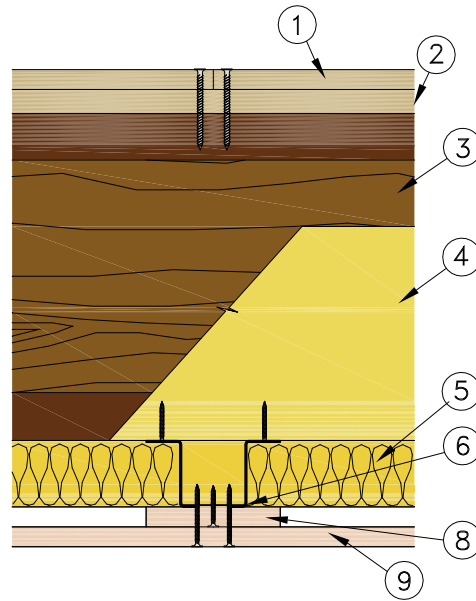

Detail along beams

Introduction:

Engineered joists enable greater spans to be achieved at lower floor loadings. However, they are also more vulnerable in fire. This construction provides 60 minutes fire resistance (insulation, integrity and loadbearing capacity) to fire from below whilst enabling high levels of insulation to be incorporated to meet current Building Regulations, for exposed floors with accommodation above.

Construction:

- 1) Tongue and groove chipboard, minimum 15mm thick, laid at right angles to the OSB flooring, and fastened through the OSB board to joists using M5 x 60mm long steel self-drilling wood screws, two screws are fitted per 600mm board width at each joist.
- 2) Oriented strand board (OSB) flooring, minimum 18mm thick, fastened to joists using M5 x 40mm long steel self-drilling wood screws. Two screws are fitted per board width at each joist.
- 3) Engineered timber joists minimum 245mm deep, at maximum 600mm centres. The joists must be of sufficient strength to support the maximum design loading for the floor at the required span.
- 4) 160mm thick x 30kg/m³ (minimum) density rock wool insulation, positioned between the timber joists on top of the top hat sections.
- 5) 50mm thick x 34kg/m³ (minimum) density rock wool insulation, fitted between the top hat sections on top of the board ceiling.
- 6) Steel top hat sections, 50mm web x 50mm flanges x 25mm lips x 1.0mm thick, fixed to the underside of the joists with M4 x 30mm long steel wood screws, through both lips of the section at maximum 600mm centres. Top hat sections fixed perpendicular to joists.
- 7) Board joints parallel with the joists are backed with a strip of PROMATECT® -250 board, 100mm wide x 15mm thick. Board joints parallel with the top hat sections coincide with those sections.
- 8) Fillets of PROMATECT® -250 board, 100mm wide x 15mm thick, are fastened to the underside of the top hat sections with 30mm long steel drywall screws at 400mm maximum centres.
- 9) A single layer of PROMATECT® -250 board, 15mm thick, is fastened to the top hat sections, through the fillets, with 45mm long steel drywall screws at 200mm maximum centres.

Fire Performance: 60 minutes in terms of loadbearing capacity, integrity and insulation performance criteria of BS 476: Part 21: 1987

AUTHORITY: WF Assessment Report Number: 160866

Technical Data
Sheet – 050

Page 1 of 1
(November 2007)



Promat UK Limited
Technical Services Department
The Sterling Centre, Eastern Road
Bracknell, Berkshire RG12 2TD
Tel: 01344 381 400
Fax: 01344 381 401
E-mail: technicaluk@promat.co.uk

