

Introduction

In general, the use of different passive fire protection systems on individual structural steel or elements of construction should be avoided. Overlapping or abutting systems can behave in different ways in fire, depending on the products involved.

This situation may specifically be encountered when beams and columns are protected using different systems. A common example of this will be where structural steel beams are protected with Promat TD Board®, and abut structural steel columns protected with PROMATECT®-250.



Both are board protection systems, and fortunately the synergy between them is well understood by Promat, enabling the following details to be provided for the interface between the two systems.

Attention must be given to the order of installation of the two protection systems, and to the differences in product thickness that may be encountered where they come together.

Where situations not covered here are encountered, the general principle is to cap off both sections of material fully into the webs of the steel, and provide a cover strip in one of the two boards. The cover strip should be fastened on one side of the overlapping joint only, fastening the cover strip to the like material.

The method follows the guidance given in the ASFP technical guidance note: ASFP TGN008 (23rd March 2008) 'Guidance on the junction between different fire protection systems when applied to load bearing structural steel elements'. The guidance note can be found on the ASFP website at: http://asfp.associationhouse.org.uk/default.php?cmd=210&doc_category=16

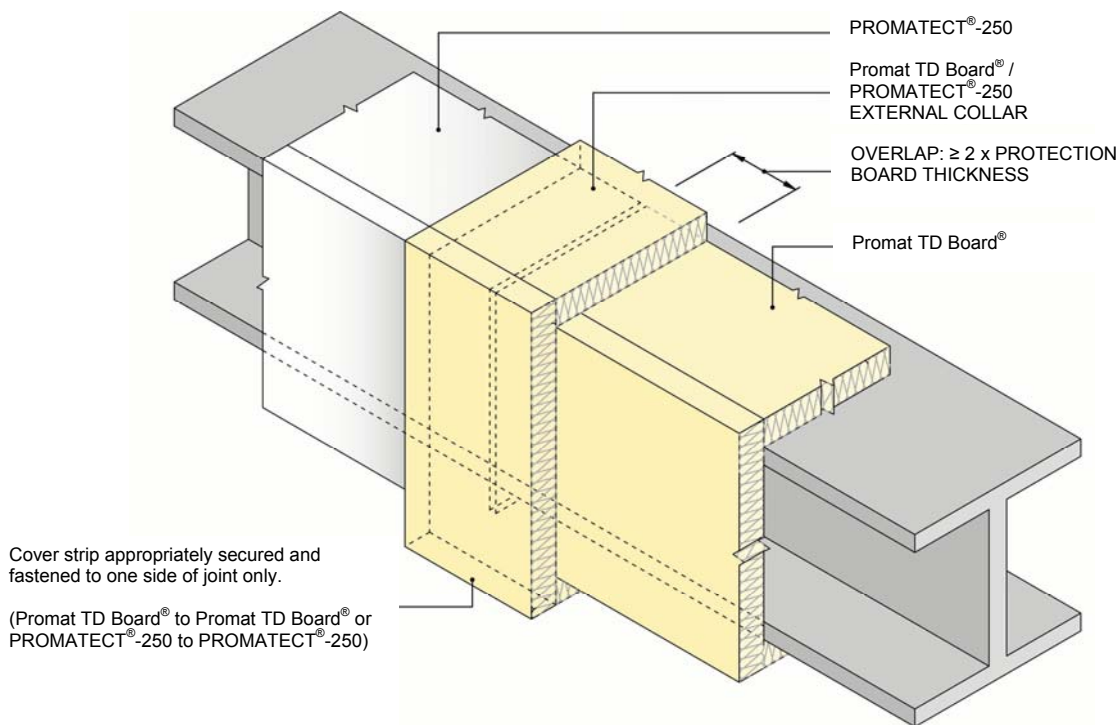

AUTHORITY: Promat Recommendation - Based on in-house knowledge and Technical Experience

Technical Data Sheet – 060

Page 1 of 3
(Sept 2008 rev 1)



Promat UK Limited
 Technical Services Department
 The Sterling Centre, Eastern Road
 Bracknell, Berkshire RG12 2TD
 Tel: 01344 381 400
 Fax: 01344 381 401
 E-mail: technicaluk@promat.co.uk



Where the thickness of the two protection materials are the same, the overlapping cover strip, (which may be in either of the materials), may be applied as a simple cover strip, fastening the cover strip to the like material below.

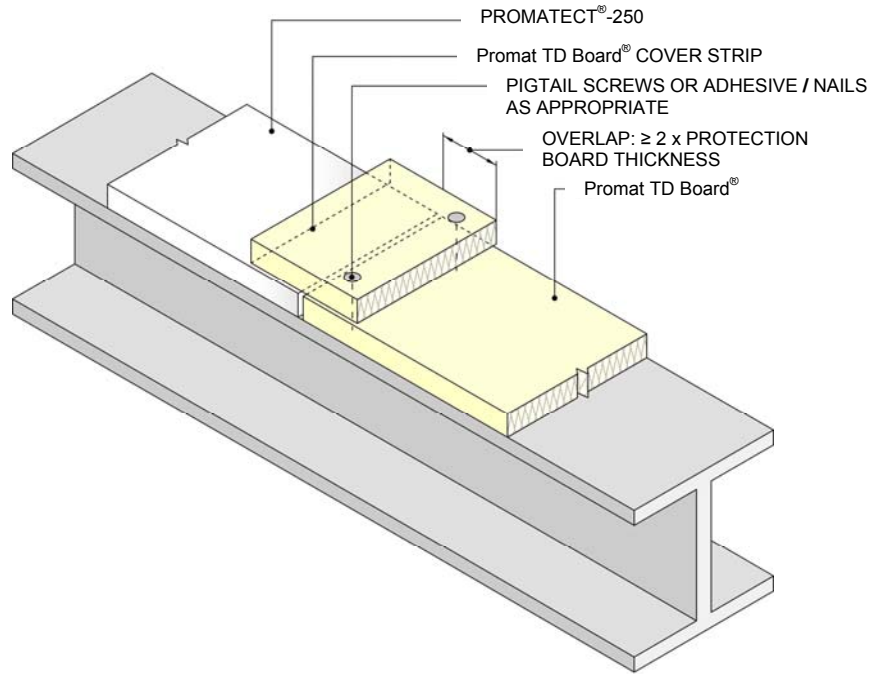

Where the thickness of the adjacent fire protection cladding materials is different, then either a packing strip is required, or a return closure piece will be needed.

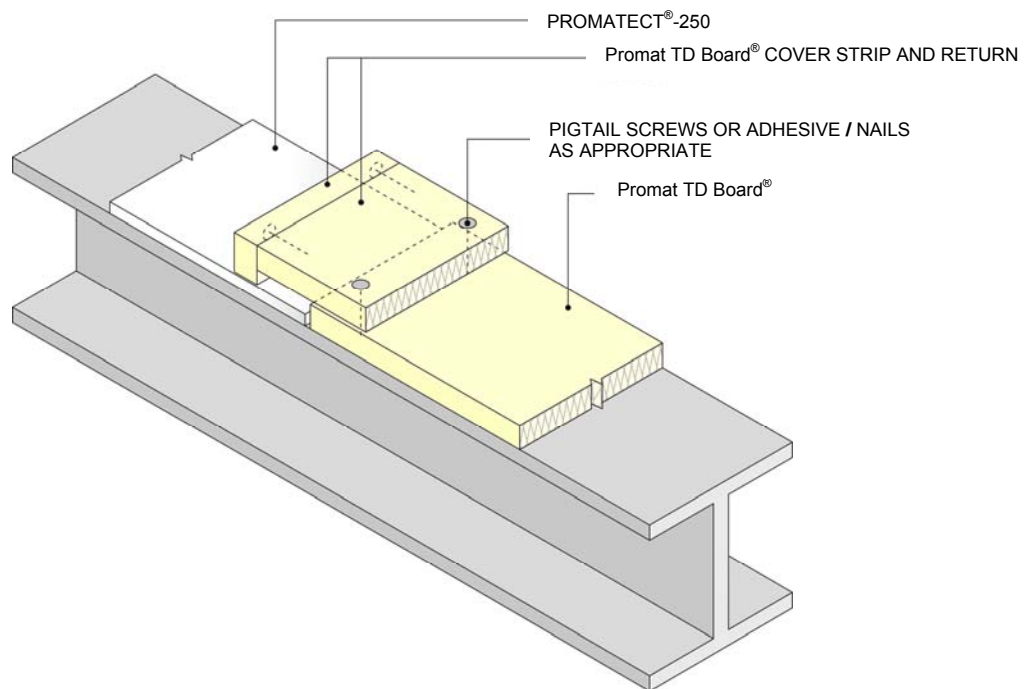

AUTHORITY: Promat Recommendation - Based on in-house knowledge and Technical Experience

Technical Data Sheet – 060

Page 2 of 3
(Sept 2008 rev 1)



Promat UK Limited
 Technical Services Department
 The Sterling Centre, Eastern Road
 Bracknell, Berkshire RG12 2TD
 Tel: 01344 381 400
 Fax: 01344 381 401
 E-mail: technicaluk@promat.co.uk



Typical Column Head Detail

The joint in the cladding protection can occur on either the steel beam or steel column, but not at the actual intersection between the two steel sections.

In practice, it is more usual to clad the whole of the beam system, including the top of the column, and to form a circumferential joint a little way down from the column head. This will normally be located above the level of any suspended ceiling.

Where the interface is on the column section, it will be necessary to finish with a nogging into the column web in order to support the end of the beam cladding board.

(This may be full depth depending upon the fixing method being used.)

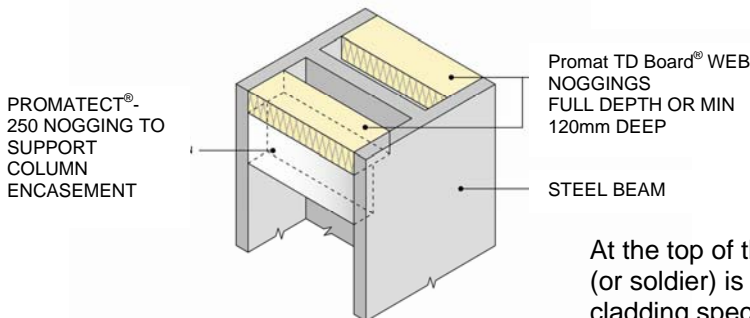
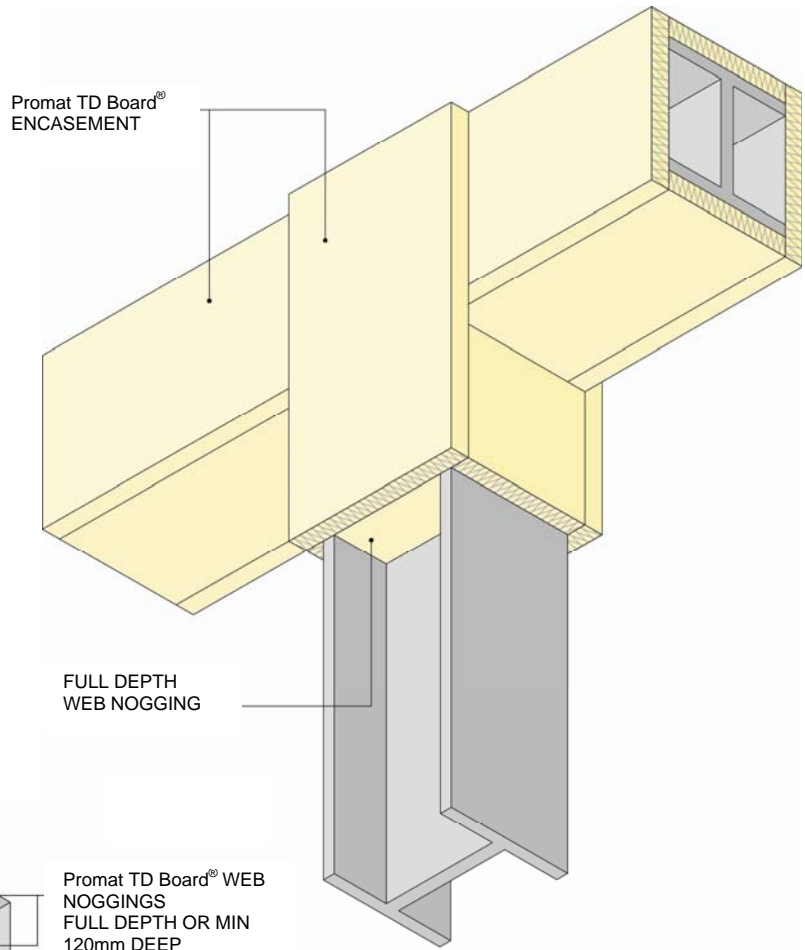

At the top of the column cladding a support noggin (or soldier) is required as part of the column cladding specification to support the column casing.

If the interface is located on the beam sections then a PROMATECT® 250 noggin (or soldier) is not necessary, and the Promat TD Board® nogging will suffice.

(The external cover strip is still required, but has been omitted for clarity.)

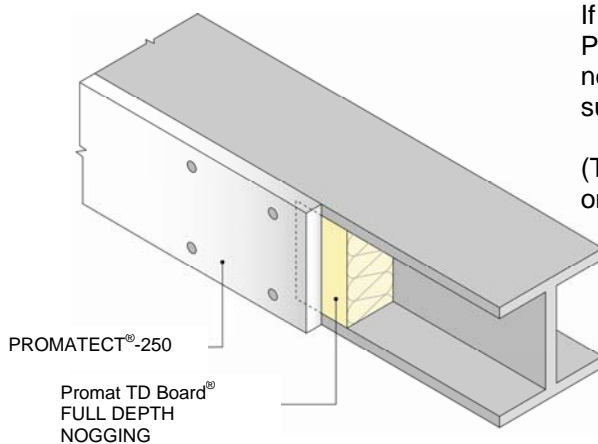

AUTHORITY: Promat Recommendation - Based on in-house knowledge and Technical Experience

Technical Data Sheet – 060

Page 3 of 3
(Sept 2008 rev 1)



Promat UK Limited
 Technical Services Department
 The Sterling Centre, Eastern Road
 Bracknell, Berkshire RG12 2TD
 Tel: 01344 381 400
 Fax: 01344 381 401
 E-mail: technicaluk@promat.co.uk

