

Introduction:

Where a carbon or steel strip, bonded with an epoxy adhesive system, is used to provide reinforcement to a concrete deck, or a down-stand beam, the adhesive system weakens very rapidly at temperatures above 60°C.

In order to maintain the load bearing capacity of the concrete element in fire, PROMATECT®-L500 fire protection can be used to ensure that a temperature of 60°C is not exceeded at any point on the adhesive bonding.

The thickness of PROMATECT®-L500 board required to achieve this is given in the table of fire performance.

It is also particularly important that the fire protection is fully sealed at the joints, and at the interface with the concrete surface, for the protection to be effective.

Detail A: Protection to Steel Reinforcement

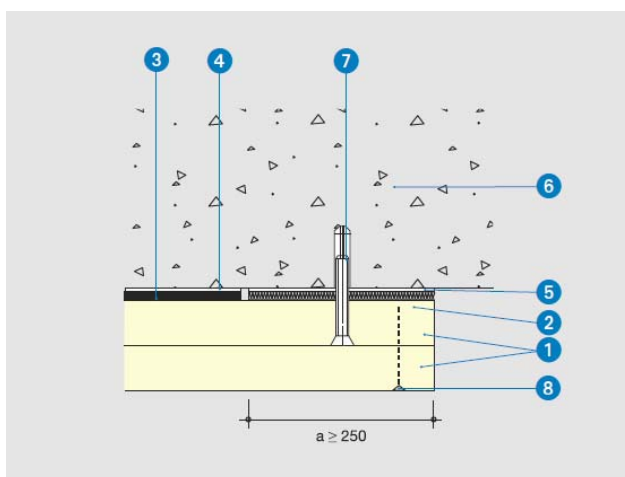

Detail B: Protection to Carbon Fibre Reinforcement

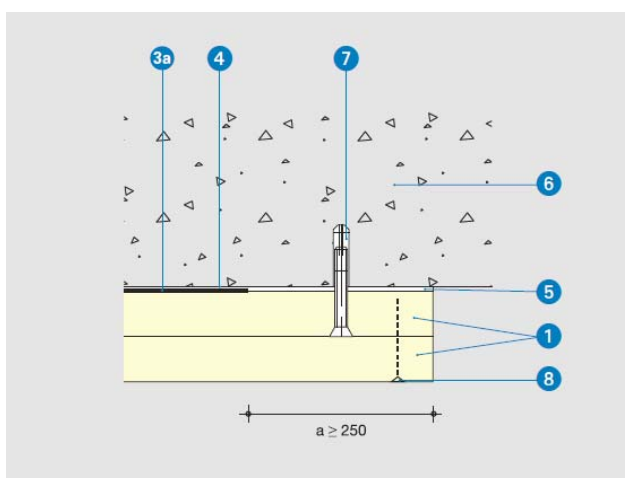

Table of Fire Performance

Period of Fire Resistance	Thickness of PROMATECT®-L500
30 minutes	2 x 25mm*
60 minutes	2 x 30mm*
90 minutes	2 x 40mm*
120 minutes	2 x 50mm

* Estimated thickness required, based on the 2hr fire test performance (CTICM test report: No 03-F-222)

- (1) PROMATECT®-L500 - Thickness according to the table above, with joints between the two layers staggered by a minimum of 500 mm.
- (2) Rock wool or SUPALUX®, thickness according to the thickness of the epoxy reinforcement layer.
- (3) Reinforcement using steel strip
- (3a) Reinforcement using carbon fibre
- (4) Epoxy adhesive reinforcement bonding system
- (5) VICUBOND® WR
- (6) Concrete deck
- (7) M6 expanding anchor (steel) at 500mm centres, (minimum 40mm penetration into the concrete).
- (8) Resin coated staples at 100 mm centres or screw fixed using M4 screws at 200 mm – the length of the fixings to be twice the thickness of PROMATECT®-L500 board, less 10 mm.

Detail A

The thickness of the *steel* reinforcement (3) is typically between 4-10mm. In order to make the seal between the concrete (6) and the PROMATECT®-L500 board protection (1), a strip of rock wool (2) is compressed and bonded between the board and soffit, using VICUBOND® WR adhesive (5). The thickness of the rock wool strip depends on the thickness of the reinforcement. (Alternatively a layer of SUPALUX® of appropriate thickness may similarly be bonded in place). The second layer of PROMATECT®-L500 (1) is fastened to the first layer using resin-coated staples or M4 screws (8).

Detail B

Where *carbon fibre* reinforcement is used, the thickness of reinforcement *may* be thin enough for the VICUBOND® WR (5) to make the seal between the PROMATECT®-L500 boards (1) and the concrete deck (6) without requiring a rock wool, or a SUPALUX® spacer.

AUTHORITY: CTICM test report: No. 03-F-222

Technical Data Sheet – 117

Page 1 of 2
(May 2009)



Promat UK Limited
Technical Services Department
The Sterling Centre, Eastern Road
Bracknell, Berkshire RG12 2TD
Tel: 01344 381 400
Fax: 01344 381 401
E-mail: technicaluk@promat.co.uk



Detail C: Joint details between boards

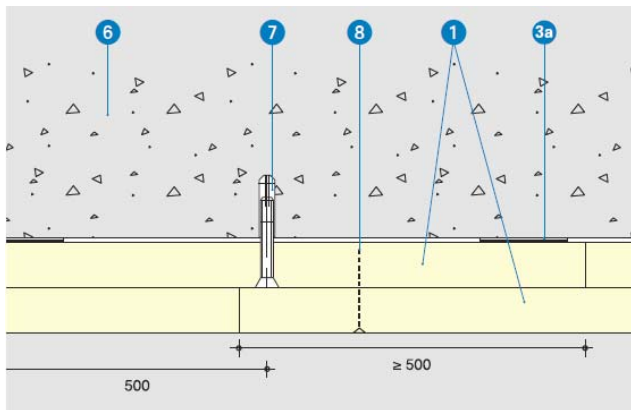

Detail C

Joints in the PROMATECT®-L500 boards (1) are staggered by a minimum of 500mm. The M6 steel expanding anchors (7) are installed at maximum 500mm centres and must penetrate the concrete by a minimum of 40mm. Note that the anchors must not puncture the epoxy bonded reinforcement strips.

Detail D: Construction at edge of concrete slab

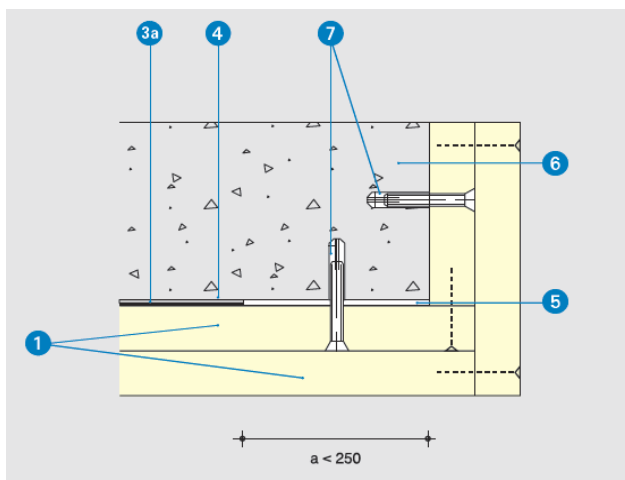

Detail D

If the distance from the edge of the reinforcement to the edge of the concrete slab is less than 250mm, then the PROMATECT®-L500 board protection should be returned up the face of the slab to prevent indirect heating of the reinforcement strip through the concrete return face.

All board to board PROMATECT®-L500 joints should be sealed using VICUBOND® WR adhesive, and fastened using resin coated staples or M4 screws.

Detail E: Return construction at down-stand beams

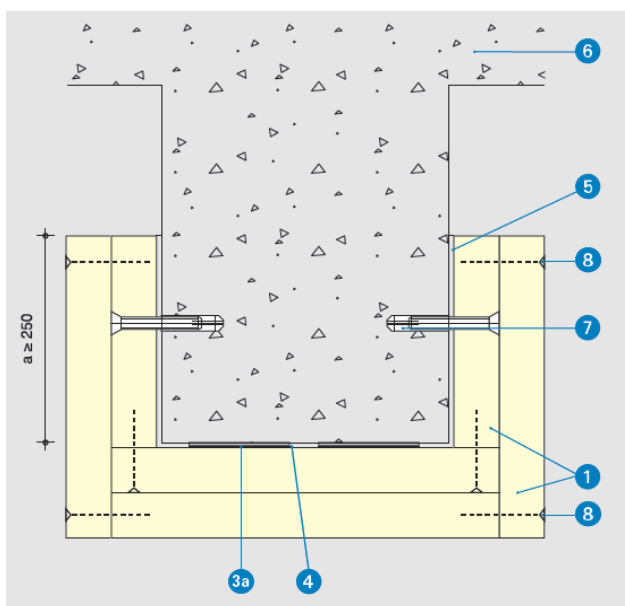

Detail E

In the situation where the reinforcement is applied to down-stand beams, the PROMATECT®-L500 board protection should be extended up the beam face by a minimum of 250mm to avoid any indirect heating of the reinforcement through the concrete beam face.

All board to board PROMATECT®-L500 joints (1) should be sealed using VICUBOND® WR adhesive and fastened using resin coated staples or M4 screws (8).

AUTHORITY: CTICM test report: No. 03-F-222

Technical Data
Sheet – 117

Page 2 of 2
(May 2009)



Promat UK Limited
Technical Services Department
The Sterling Centre, Eastern Road
Bracknell, Berkshire RG12 2TD
Tel: 01344 381 400
Fax: 01344 381 401
E-mail: technicaluk@promat.co.uk

