

Promat have developed a fire resistant shaftwall system that can be installed prior to the building being 'dry'. Using specially treated Promat SUPALUX® boards, it is now possible to install the shaftwalls as soon as the concrete cores and floors have been constructed. This allows other trades to start earlier, thus speeding up the building programme.

This system is applicable for use in those areas requiring 60 minute and 120 minute integrity and insulation performance, but where access for construction is possible from one side only e.g. lift shaft walls and risers.

- Up to 120 minutes fire resistance.
- System can be built in an open environment.
- System can be built from one side only – removing the need for scaffolding in the shaft.
- No latent defects due to water.
- Releases building cores for services significantly earlier.
- Overall programme saving.
- Comparable installation time to traditional dry lining.
- Shaft wall nominal thickness of 122mm.
- Designed for wall heights of up to 5.5 metres.
- An NBS for the SUPALUX® shaftwall system is available.
- Acoustic data: 60 minute system  $R_w$  43-44 dB.  
120 minute system  $R_w$  44-45 dB.



### Construction details:

- Promat SUPALUX® IMPREGNATED boards 9mm thick
- Steel DOUBLE E profile channel 92.8 x 50 x 0.7mm located at 600mm centres.
- Steel SINGLE E profile channel 92.8 x 25 x 0.7mm located at corners and wall abutments.
- Steel FLOOR TRACK channel 60 x 94 x 40 x 0.7mm fixed at maximum 600mm centres using M6 steel anchor bolt.
- Steel HEAD TRACK channel 60 x 94 x 60 x 0.7mm fixed at maximum 600mm centres using M6 steel anchor bolt.
- Promat SUPALUX® cover strip 9mm thick x 100mm wide at all horizontal board joints.
- Rock wool 80mm thick, applied in staggered layers, fitted between channels.
  - 2 x 40mm x 45 kg/m<sup>3</sup> for 60 minutes fire protection.
  - 2 x 40mm x 100 kg/m<sup>3</sup> for 120 minutes fire protection.
- Promat SUPALUX® fillet, 20mm thick x 100mm wide fixed through steel channels with 4.2mm self tapping or self drilling screws at 200mm centres.
- All perimeter channels to be bedded onto Promat PROMASEAL® Intumescent Acrylic Sealant. Promaseal® Intumescent acrylic sealant also to be used to seal all gaps and abutments.

### Shaft side:

9mm x 600mm wide SUPALUX® IMPREGNATED boards friction fitted between studs. Boards butt jointed together and horizontal board joints backed using 9mm x 100mm wide SUPALUX® coverstrip, fixed using 25mm x M3.5 steel self drilling and tapping screws at 200mm centres, fixed on both sides of the joint.

### Corridor side:

20mm SUPALUX® fillet strip fixed to face of E-profile channels using 32mm drywall screws at 500mm centres.  
9mm SUPALUX® boards butted together and screw fixed through the 20mm fillet to all framework members using 42mm x M3.5 steel self drilling and tapping screws at 200mm centres.  
Horizontal board joints backed using 9mm x 100mm wide SUPALUX® coverstrip, fixed using 25mm x M3.5 steel self drilling and tapping screws at 200mm centres, fixed on both sides of the joint.

### NOTES:

- For the 120 minute system, the temperature of the exposed metal, on the shaft side of the construction, may exceed the requirements of BS 476: Part 22: 1987 within the fire test period.  
Relaxation should be sought on the basis that no combustible materials are likely to be stored adjacent to the structure. Alternatively, for full fire insulation, SUPALUX fillet 15mm thick x 100mm wide should be fixed to exposed metal on the shaft side of the construction. Cover strip fixed with M3.5 steel self drilling & tapping screws at nominal 200mm centres.
- Maximum height 5.5 metres. Contact Promat Customer Relations team if shaftwall height above 4 metres is required.

**AUTHORITY:** Exova Warringtonfire WF195196

**Technical Data Sheet – 155**

Page 1 of 2  
(Nov 2011)



**Promat UK Limited**  
Customer Relations Team  
The Sterling Centre, Eastern Road  
Bracknell, Berkshire RG12 2TD  
Tel: 01344 381 400  
Fax: 01344 381 401  
E-mail: [technicaluk@promat.co.uk](mailto:technicaluk@promat.co.uk)



### Shaftwall System

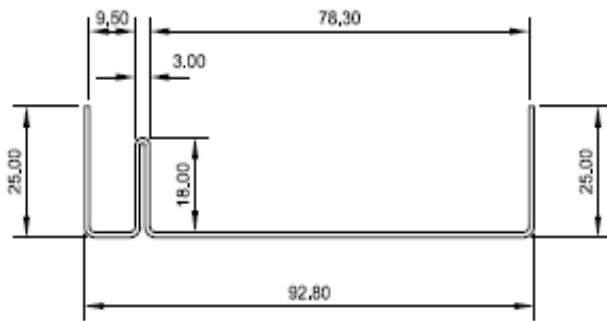

**Vertical Stud Single 'E' Profile**  
92.8mm x 25.0mm x 0.7mm  
4000mm length

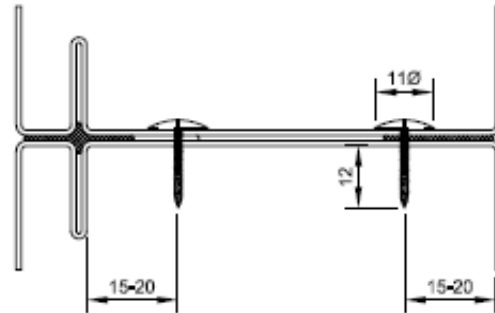

**Vertical Stud Double 'E' Profile**  
92.8mm x 50.0mm x 0.7mm  
4000mm length

Double E profile fabricated by joining two single E profile channels, screw fixed using 13mm x M4 (No.8) steel self tapping screws or M4 blind rivets at 300mm centres, applied in two rows. 2 continuous beads of Promaseal® intumescent Acrylic sealant applied to back of studs before fixing them together.

Single and double E-studs at nominal 600mm centres may be fixed to the base channel but are a sliding fit in the head channel, with an allowance for longitudinal thermal expansion of at least 5mm per metre height.

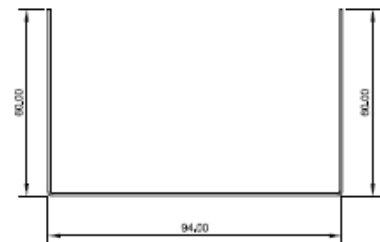
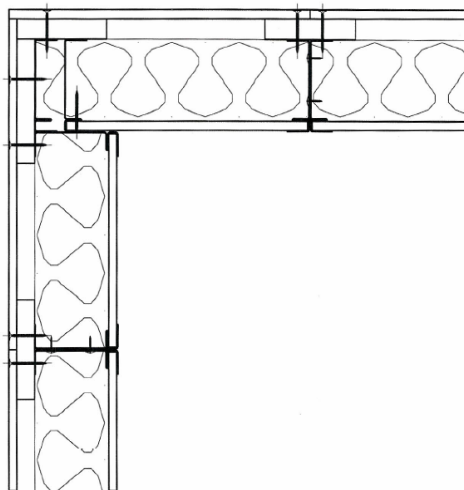

**Head Track Detail**  
60mm x 94mm x 60mm x 0.7mm  
3000mm length

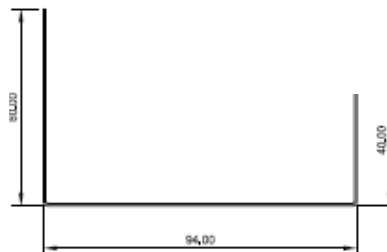

**Floor Track Detail**  
60mm x 94mm x 40mm x 0.7mm  
3000mm length

### Supalux Shaftwall® Corner detail

- It is assumed that the shaftwall system is supported from appropriate masonry/concrete or steel constructions that have a fire resistance of at least the same as that required by the partition system and are capable of providing adequate support to the constructions for the required period of fire resistance.
- Where partitions are erected against a steel structure, it is a requirement that the steelwork is fire protected with a product to maintain steel protection and compartmentation. Please contact Promat UK Customer Relations team for details of suitable products to provide this required fire protection.
- Fire resistant penetrations can be achieved using the Promat PROMASEAL® range of fire stopping products.

**AUTHORITY:** Exova Warringtonfire WF195196

Technical Data  
Sheet – 155

Page 2 of 2  
(November 2011)



**Promat UK Limited**  
Customer Relations Team  
The Sterling Centre, Eastern Road  
Bracknell, Berkshire RG12 2TD  
Tel: 01344 381 400  
Fax: 01344 381 401  
E-mail: technicaluk@promat.co.uk

