

## DURASTEEL® COMPOSITE BARRIER SYSTEM

### CONSTRUCTION

1. Head and base track 80mm x 60mm x 3mm thick steel channel fixed to floor slab and soffit with M10 or M12 all-steel expanding anchors (or equivalent for alternative types of construction) at 500mm maximum centres. Floor slab and soffit to have minimum of the same level of fire protection as that required by barrier.
2. Steel channel framework 80mm x 60mm x 3mm channel (1). Vertical channels at maximum 1200 mm centres, Horizontal channels at maximum 2000 mm centres. For partition heights up to 4 metres, horizontal and vertical channel members may be welded together or joined with steel angle cleats, minimum 60mm x 60mm x 3mm thick x 60mm long, fastened to each channel member with two M10 steel bolts and nuts. Above 4 metre height the horizontal and vertical channel members are joined with the angle cleats. Wherever possible, the main vertical channel studs should be formed in one continuous length to avoid the need for splicing.
3. One layer of 12mm thick PROMATECT® -250 (2) fixed on both sides of the wall using countersunk ribbed timber-fix Tek screws at 600mm centres. Vertical board joints coincide with studs. Horizontal board joints are fitted with an internal 100mm wide x 12mm PROMATECT® 250 (4) cover strip, fixed both sides of the joint with steel drywall screws at 250mm nominal centres.
4. 9.5mm thick DURASTEEL® sheet (3), fastened to the framework, through the PROMATECT® -250 boards, on both sides of the wall using M5.5 steel self drill and tapping Tek screws at 250mm nominal centres. Fixings a minimum of 12mm and maximum 20mm from board edge and a minimum 50mm and maximum 100mm from corners (ie 2 fixings per corner) in accordance with the Etex Building Performance Limited Durasteel corner fixing statement. The length of fixing to be sufficient to ensure appropriate penetration of screw thread, in accordance with recommendations from the fixing manufacturer.

Vertical joints coincide with the studs. Horizontal board joints coincide with the horizontal channels or are fitted with an internal steel cover strip, 100mm wide x 3mm thick, fastened on both sides of the joint with M5.5 steel self drill and tap Tek screws at 250mm nominal centres.

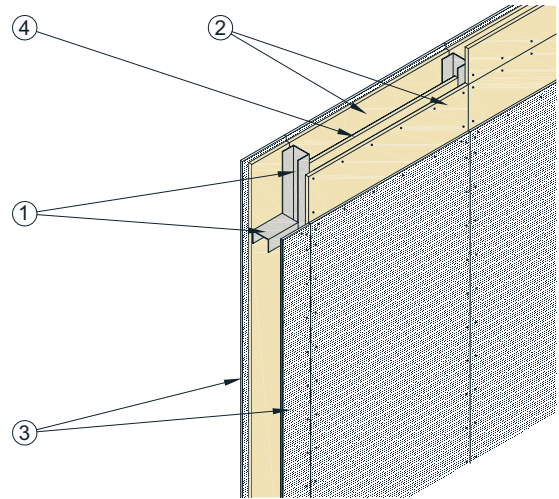

Height of Partition	Size of Channel Stud Required	Acoustic Sound Insulation Rw (assessed)
Up to 9m	80mm x 60mm x 3mm thick	43 dB
9m – 12m	150mm x 60mm x 3mm thick	45 dB
12m – 15m	175mm x 60mm x 3mm thick	46 dB

Up to a height of 4m no expansion allowance is required. Above that height an expansion allowance of at least 6mm per metre height is required. Where an expansion allowance is provided at the top of a partition, steel channels, minimum 50mm flanges x 3mm thick, are fastened to the vertical channels with M10 steel bolts and nuts. The width of the channel (web dimensions) should be such that it is a close fit within the channel studs. At the junction above the expansion gap the channels are connected with minimum two M10 bolts. At the junction below the expansion gap the channels are connected, through slotted holes, with minimum two M10 bolts fitted with fusible washers. The gap in the DURASTEEL® and PROMATECT® 250 board facing is covered with a DURASTEEL® and PROMATECT® 250 board cover panel that is fastened to the steel framework above the gap (through the facing boards) and overlaps the facing boards below the gap by at least 75mm.

AUTHORITY: CERTIFIRE NO CF 607 AIRO ACOUSTIC ASSESSMENT L3093/L1

